



*A bespoke all-in-one solution for creating seamless displays to transform any window display*

## High Brightness Indoor DV-LED Displays P2.5

With unparalleled flexibility and limitless creativity, DV-LED offers immersive experiences that are impossible to ignore. In today's bustling world, it's all about the power of visual impact, as businesses must embrace innovative ways to captivate audiences and make their messages stand out. As a versatile tool, Direct View LED unlocks the potential for truly captivating visuals, ensuring your messages always make a statement.

### **High Brightness Indoor DV-LED Highlights**

- Ultra High Brightness (2,200cd/m<sup>2</sup>)
- Complete window display solution
- Front Serviceability
- Easy Installation Cabinet Design
- End to End Project Management



## Main Features

### Complete Packaged Solution

This all-in-one package contains everything needed to get your display up and running, including the LED modules and mounting bracket. For larger DV-LED video walls an aluminium screen edge can also be made to order at no additional cost, protecting the display and improving the overall aesthetic.



LED Modules

+

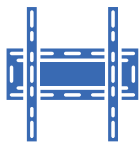

Mounting Bracket

+

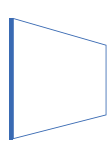

Protection Edge



### Captivating Image Quality

By utilising state-of-the-art SMD technology and advanced video processing, these displays really bring content to life by delivering crystal clarity and lifelike colours without any distortion. This is coupled with rapid refresh rates to ensure seamless content playback.



### Compact Diode Package

These displays feature an exceptionally small diode package size, increasing the space between diodes to achieve an ultra-high 6,500:1 contrast ratio. This ensures vibrant colours and true blacks across the display without sacrificing brightness, creating a truly immersive viewing experience.



6,500:1  
Contrast Ratio



### Easy Installation & Maintenance

Thanks to their lightweight design, magnetic modules, positioning pins and simple cabinet structure, these displays are incredibly easy to install. Made from robust aluminium, the cabinets are warp-resistant, ensuring perfect alignment for a flawless finish. After installation, they can be serviced from the front of the display by quickly and efficiently removing the DV-LED modules for ultimate ease of maintenance.



### UK Stock Held

Our fully-stocked UK warehouse means we can fulfil projects with a rapid turnaround time if required. From initial enquiry to finished installation, by holding extensive stock in the UK we can deliver results without long delays.



## Other Features

### End-to-End Project Management

We understand that every Direct View LED project is unique and each comes with their own set of challenges. In order to help our partners embrace this innovative technology, we are offering full end-to-end project management. From design to installation, our team is dedicated to assisting you every step of the way.

Bespoke displays can be developed to accommodate specific project requirements, installation of the Video Walls can be carried out or assisted by team members to ensure a hassle-free process, and maintenance can be provided when necessary. This all guarantees easy accessibility to the solutions for both you and your customers.

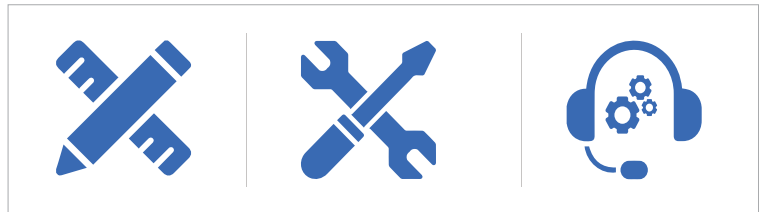

Design

>>

Installation

>>

Maintenance

### Bespoke Video Walls

Thanks to their modular design, these versatile displays are not constrained by standard aspect ratios. Stand out from the crowd by sculpting seamless large-scale video walls to fill spaces of any shape and size in any location. The unique cabinet size gives ultimate flexibility by ensuring a 16:9 aspect ratio is also possible.



### Ultra-Quiet Operation

These DV-LED displays do not require cooling fans due to their super low heat emissions. Not only does this allow them to run silently, which is especially important in indoor spaces, it also makes them more robust and reliable as there are no moving parts.



### Remote Content Updates

Publish and monitor content from anywhere in the world via the internet using our own cloud-based CMS software, which is designed to be cost-effective and user-friendly. Plus, avoid the hassle associated with coordinating multiple suppliers by sourcing hardware and software from one place.



### Comprehensive Quality Control

From production through to installation, our DV-LED solutions undergo multiple rounds of strict quality control to ensure long-lasting reliability. In addition, quality calibration guarantees consistent image quality across the whole display.



## Specification Table

		P2.5
LED Display	Pixel Pitch (mm)	2.5
	LED Type	SMD2121
	Pixel Configuration	1R1G1B
	Brightness (Calibrated)	2,200cd/m <sup>2</sup>
	Refresh Rate	3840Hz
	Contrast Ratio	6,500:1
	Viewing Angle - Horizontal	170°
	Viewing Angle - Vertical	170°
	Processing	12 bit
	Frame Rate	60 fps
	Maintenance	Front service
Cabinet	Module Resolution (px)	128x64
	Module Size (mm)	320x160x14.5
	Cabinet Resolution (px)	256x192
	Cabinet Size (mm)	640x480x31.4
	Net Weight (Kg)	6.2
Power	Input Voltage	240V AC
	Cabinet Current	<0.45A
	Average Power Consumption (Per Cabinet)	32W
	Max Power Consumption (Per Cabinet)	96W
	Standby Power Consumption (Per Cabinet)	0.5W
Environmental	IP Rating	TBC
	Operating Temperature	-10°C to +30°C
	Storage Temperature	-20°C to +40°C
	Operating Humidity	10% to 65%
	Storage Humidity	10% to 60%
	Lifetime	100,000 hours
Warranty	Warranty Period	3 Year Warranty
	Technical Support	Lifetime



# Cabinet Technical Drawing

---

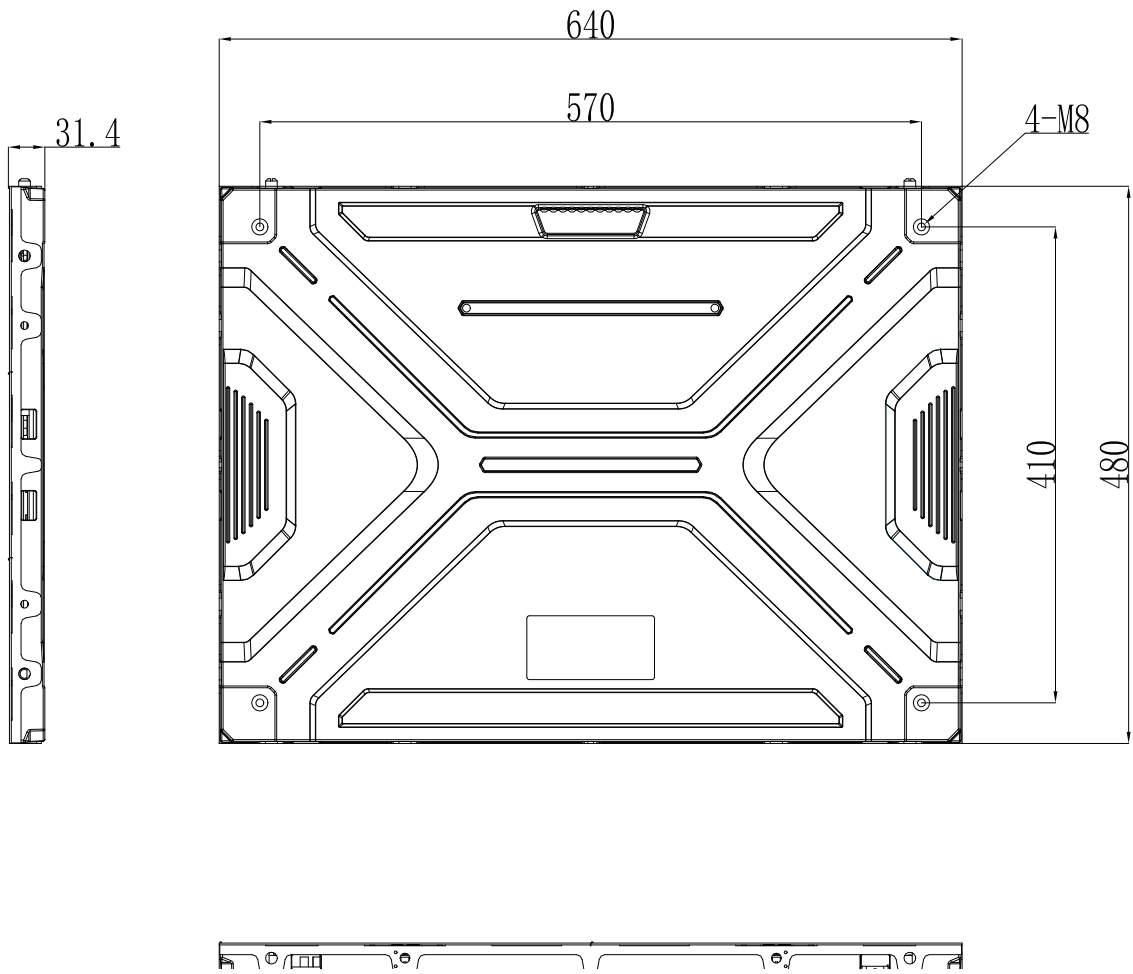

# Why Choose Our Commercial Display Solutions?



## Lifetime Technical Support

From the moment you receive your product, throughout the duration of your warranty and even after your warranty has expired we are here to support you. If you require any assistance setting up or using your product, or have any problems at all, we can provide free technical support via telephone and email.



## On-site Support and Maintenance\*

If needed, we can provide an installation service for any of our products. We can also set up service-level agreements for larger projects that require maintenance contracts.



## Extended Warranty\*

All of our commercial display products come with a 3 year commercial warranty as standard but if you want to extend this you can upgrade this to cover a 5 year period at point of purchase.



## Training

As well as providing free remote CMS training sessions and webinars we can also visit you to deliver bespoke training for our software and hardware\*.



## Advanced Replacements†

Should your display suffer from any kind of hardware failure during the warranty period we will send you an advanced replacement and arrange for your old display to be collected, free of charge. This ensures no downtime where you are without a screen.



## Custom Product Testing & Configuration

If you need us to test third party software or a website, or configure your screen in a particular way before it is dispatched (e.g. in a particular orientation or network mode), we can do so to make your life easier.



## 3D Rendering

Want to know how a particular screen will look once installed? Send us a photo of the location and we will create a 3D rendering of any screen in situ to help you to visualise how amazing it will look.



## Logistics Support

We hold more stock in our UK warehouse than any other manufacturer so we can help you meet tight deadlines. For last minute orders we can also offer special express or morning delivery options\*. We also carry out UK based quality control checks on every display before it leaves our warehouse.



## Project Support

If you need to loan a sample unit to test we'd be more than happy to arrange this. We can also provide a rental service for temporary projects\*.



## Customisation\*

Your display can be customised to suit your requirements by adding your logo or printed graphics or even tailoring the colour of a display. We can also carry out hardware modifications to existing products or manufacture bespoke solutions for special projects.



## Extras\*

As well as being able to provide accessories and add-ons, such as extra remote controls, NUC PCs and video wall controllers, we can also supply custom made flight cases which are great if a display needs to be moved safely from place to place.

†UK mainland only

\*These particular services may incur additional charges